

Shown with optional billet
alternator # 9665 and billet
power steering pump # 9600.
Ask salesman about pricing
and adding to your kit.

***Ford 460 Alternator & Power Steering Ultra
Serpentine Kit***

***Kit # 30245 Keyway Power Steering
Kit # 30250 Press Fit Power Steering***

PARTS LIST

Alternator Bracket # 30200

1-30201-A..... Alternator Main Bracket
2-S174..... 5/16" x 5-1/2" SHCS
2-S248..... 3/8" x 1" SHCS
1-S280..... 3/8" x 5-1/2" SHCS
1-S374..... 7/16" x 5-1/2" SHCS
1-S667..... 3/8" Flat Washer
1-BS3-3.000 Alternator Bushing Spacer
2-TP3-1.680 3/8" x 1.680 Tube Spacer
1-TP7-1.890 7/16" x 1.890 Tube Spacer
1-RA-4.375 4.375 Adjustment Rod

Pulley Kit # 1875-208

1-1874-A..... Crank Pulley
1-1872-A..... Water Pump Pulley
1-620-A..... Power Steering Pulley (Press Fit)
1-535-A..... Power Steering Pulley (Keyway)
1-313-A..... Water Pump Pulley Cap
1-307-A..... Alternator Pulley Cap
1-302-A..... Power Steering Pulley Cap
1-221-A..... Alternator Fan
1-208-A..... Alternator Pulley
3-S022..... 8-32 x 3/8" SHCS
3-S028..... 8-32 x 1" SHCS
4-S186..... 5/16" x 7/8" SHCS
4-S248..... 3/8" x 1" SHCS
1-S685..... 11/16" Lock Washer

Power Steering Bracket # 30210

1-30211-A..... Power Steering Main Bracket
1-30211-B..... Power Steering Rear Support
1-S248..... 3/8" x 1" SHCS
1-S250..... 3/8 x 1-1/4" SHCS
1-S254..... 3/8" x 1-3/4" SHCS
1-S256..... 3/8" x 2" SHCS
1-S312..... 3/8" x 1" Hex Head
2-S356..... 7/16" x 2-1/4" SHCS
1-S664..... 3/8" x 1" Diameter Flat Washer
5-S666..... 3/8" x 3/8" Diameter Flat Washer
1-AC3-.650 3/8" x .650 Aluminum Spacer
1-AC3-.725 3/8" x .725 Aluminum Spacer
1-AC3-.875 3/8" x .875 Aluminum Spacer
1-AC3-1.000 3/8" x 1.000 Aluminum Spacer
1-TP3-.300 3/8" x .300 Tube Spacer
1-TP3-.800 3/8" x .800 Tube Spacer
2-TP7-1.625 7/16" x 1.625 Tube Spacer

***NOTE:** Inspect all items for any imperfections or shortages of items. If any of those instances do come up, please call our tech line that's listed below. If you prefer a color copy of these instructions, please refer to our website listed below and click the instructions tab on your product's web page. Some pulleys might have powdercoat build up and it may be necessary to remove with light grit sandpaper. These pulleys include alternator inner hole, and any pulley with a pilot shaft or locator hole.



Tech Support:
1-888-729-9070
info@marchperformance.com
www.marchperformance.com

Photo 1

Mount the crank pulley (1874-A) to the balancer using four 3/8" x 1" SHCS (S248) and tighten down. **NOTE:** If crank pulley is not going over balancer pilot shaft easily, it maybe be necessary to use light grit Scotch Bright to remove some powdercoat to help. It also helps to clean pilot shaft of balancer with sandpaper of any excess paint or grime to help.

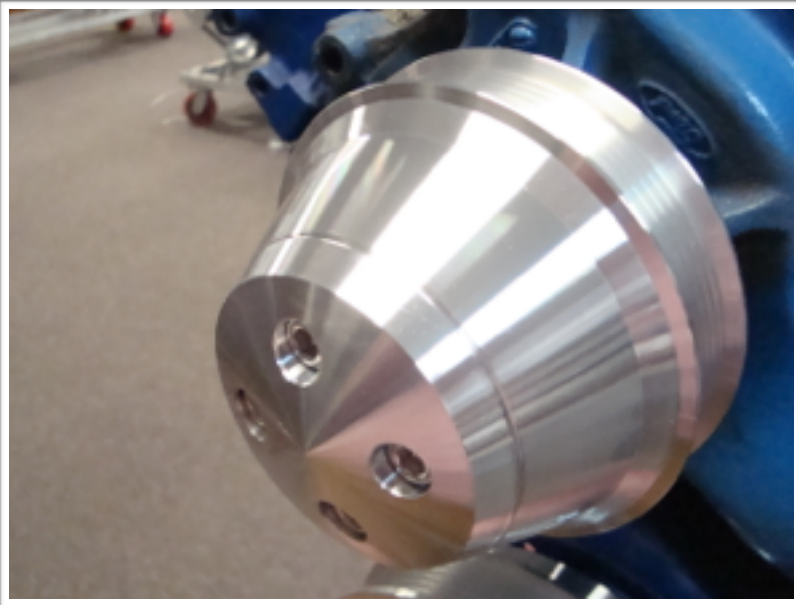
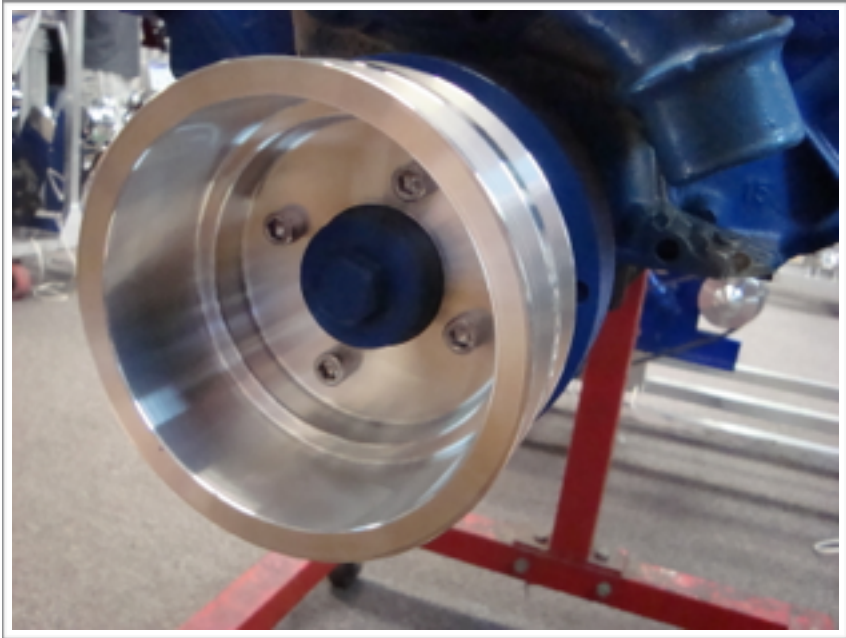

Photo 2

Install the water pump pulley (1872-A) and the (313-A) water pump cap using four 5/16" x 7/8" SHCS (S186). ***NOTE:** If using a mechanical fan **DO NOT** install the water pump cap. We **DO NOT** supply bolts for mechanical fans or adapters.

Photo 3

Install the alternator bracket (30201-A) to the water pump by running two 5/16" x 5-1/2" SHCS (S174) through the bracket. Then space bracket from water pump with two (TP3-1.680) spacer tubes and leave hand tight.





Photo 4

To mount the alternator to the bracket, hold alternator behind bracket then run a 7/16" x 5-1/2" SHCS (S374) through the bracket and alternator ear. Next place a (TP7-1.890) spacer between the head and alternator ear and tighten down bracket assembly. **NOTE:** If your head is tapped for a 3/8" hole, install the alternator bushing spacer into your alternator lower ear and run a 3/8" x 5-1/2" SHCS (S280) into the alternator and (TP7-1.890) spacer, then into the head. For alignment issues, use the supplied 3/8" washer (S667) in front or behind alternator to properly align. Not needed if head is tapped for 7/16" bolt.

Photo 5

Install the (RA-4.375) adjustment rod to the front of the upper alternator ear and water pump as shown. Use two 3/8" x 1" SHCS (S248) and tighten down.

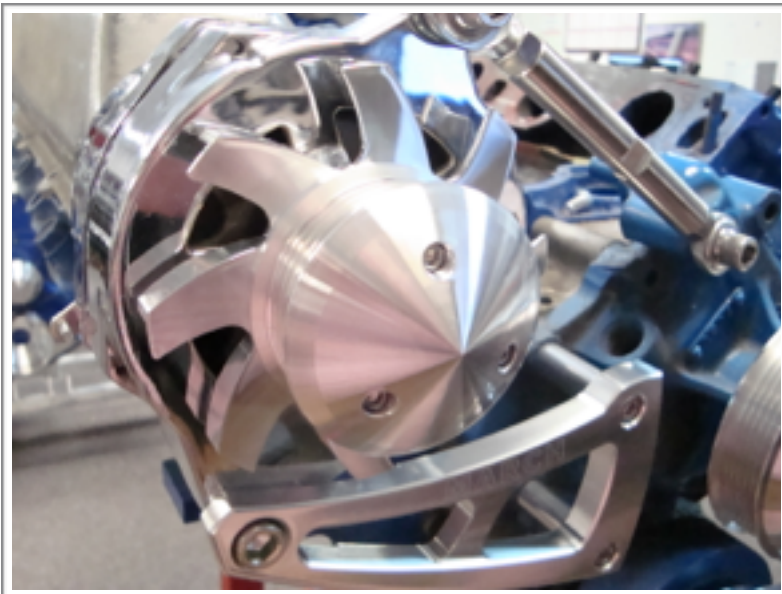

Photo 6

Install the alternator fan (221-A), then the alternator pulley (208-A). Use the provided lock washer (S685) and tighten down with the alternator nut and impact pulley on. Next add the alternator nose cover (307-A) and tighten down with three 8-32" x 1" SHCS (S028).



Photo 7

Install the power steering rear support bracket (30211-B) to the two outer head holes with two (TP7-1.625) spacer tubes between head and bracket and tighten with two 7/16" x 2-1/4" SHCS (S356).

Photo 8

Install the power steering pump to the rear support bracket placing a spacer (AC3-1.000) for steel cased saginaw pumps or a (AC3-.875) for the March billet pump 9600 in the lower hole. Secure with a 3/8" x 2" SHCS (S256) and a 3/8" washer (S666). In the upper hole place spacer (AC3-.725) for steel cased saginaw pumps or a (AC3-.650) for the March billet pump 9600. Secure with a 3/8" x 1-3/4" SHCS (S254) and a 3/8" washer (S666). Leave hand tight for now.

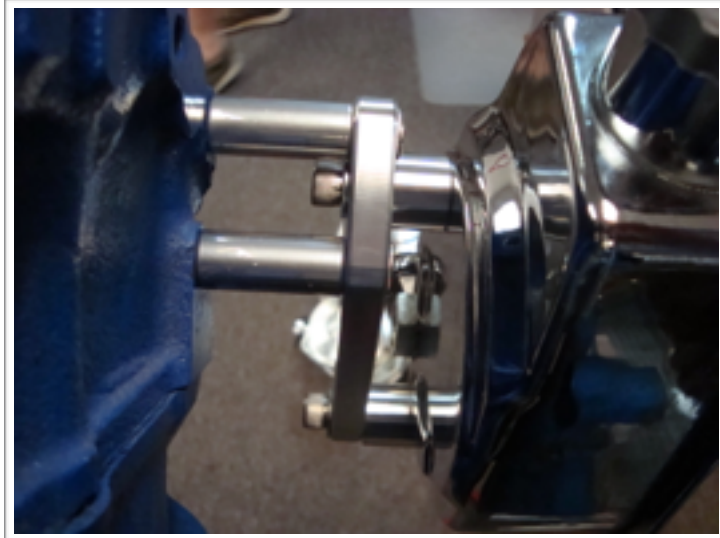

Photo 9

Install the power steering front bracket (20311-A) to the water pump by running a 3/8" x 1-1/4" SHCS (S250) with a (TP3-.800) spacer in the upper hole. In the lower hole run a 3/8" x 1" SHCS (S248) with a (TP3-.300) mounting hole and tighten.

Photo 10

Pull power steering pump up and run a 3/8" x 1" hex head bolt (S312) and a 3/8" x 1" diameter washer (S664) through adjustment slot. To align use two or three 3/8" washers (S666) between the front bracket and the power steering pump. Now install the (535-A) pulley for keyway pumps or (620-A) pulley for press fit pumps. Next install the nose cover (302-A) using three 8-32 x 3/8" SHCS (S022) and tighten.

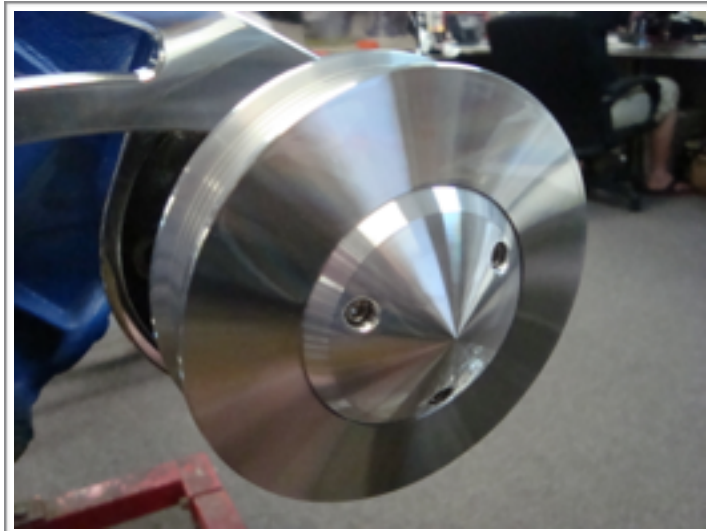
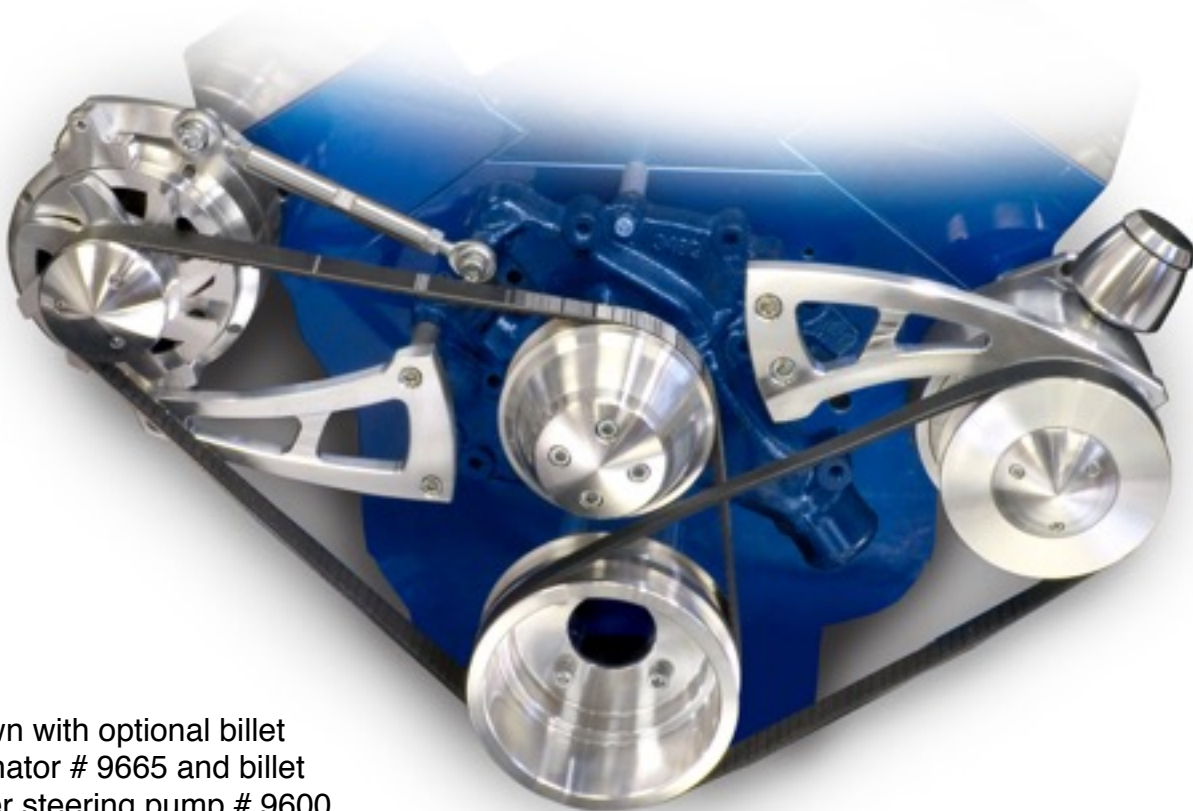

Photo 11

First install the **46-1/2" Dayco (5060465)** belt on alternator side first, tighten by turning adjustment rod expanding it outward to tighten belt. Due to belt variations in may be necessary to remove adjustment rod, install belt and re-install adjustment rod and tighten. Then install a **40" Dayco (5060400)** belt on the power steering side second. Pull down to tighten and lock down front and rear support bracket bolts. Make sure all bolts are tight on all brackets and pulleys before running engine.

***NOTE:** Due to belt variations in manufacturing it may be necessary to get belts that are either larger or smaller than we recommend. We recommend using Dayco manufactured belts.



Shown with optional billet alternator # 9665 and billet power steering pump # 9600. Ask salesman about pricing and adding to your kit.



Tech Support:
1-888-729-9070
info@marchperformance.com
www.marchperformance.com

LIMITED WARRANTY

March Performance warrants to the original retail purchaser that for a period of ninety (90) days from the date of purchase, March Performance will repair or replace, at their option, any Product, which is found to be defective in material or workmanship.

Exclusions from Warranty Coverage

March Performance does not warrant any Product that is damaged from abuse, misuse or misapplication or not used for its intended purposes.

This Limited Warranty does not cover or apply to any damage or loss sustained to the engine or any other parts which may have been caused by the defective Product and does not cover or apply to any personal injury, labor charges or any other incidental costs for damages caused by the defective Product. THIS IS THE ONLY EXPRESS WARRANTY GIVEN WITH RESPECT TO YOUR PRODUCT. ALL OTHER EXPRESS WARRANTIES, GUARANTEES, OR STATEMENTS REGARDING THE PRODUCT, WHETHER WRITTEN OR VERBAL, ARE HEREBY DEEMED NULL AND VOID AND OF NO EFFECT.

Normal wear and tear and damage to the Product not caused by March Performance are also excluded from this Warranty.

DISCLAIMER OF OTHER WARRANTIES

EXCEPT TO THE EXTENT PROHIBITED BY APPLICABLE LAW, ANY IMPLIED WARRANTY WHETHER OF MERCHANTABILITY, FITNESS FOR A PARTICULAR PURPOSE, OR WARRANTY, SOME STATES DO NOT ALLOW LIMITATIONS ON HOW LONG AN IMPLIED WARRANTY WILL LAST SO THAT THE PRECEDING LIMITATION MAY NOT APPLY TO YOU.

Limitation on Remedies

REPAIR OR REPLACEMENT AS PROVIDED IN THIS WARRANTY IS YOUR EXCLUSIVE REMEDY. MARCH PERFORMANCE SHALL NOT BE LIABLE FOR ANY INCIDENTAL OR CONSEQUENTIAL DAMAGE FOR BREACH OF ANY EXPRESS OR IMPLIED WARRANTY ON THE PRODUCT. SOME STATES DO NOT ALLOW THE EXCLUSION OR LIMITATION OF INCIDENTAL OF CONSEQUENTIAL DAMAGES SO THE PROCEEDING LIMITATIO OR EXCLUSIONS MAY NOT APPLY TO YOU. YOU HAVE NO RECOURSE OR REMEDY FOR DAMAGE OR DEFECT CAUSED BY MISUSE, ABUSE OR NEGLIGENCE.

THIS WARRANTY GIVES YOU SPECIFIC RIGHTS AND YOU MAY ALSO HAVE OTHER RIGHTS, WHICH MAY VARY FROM STATE TO STATE.

Your Responsibilities:

- 1. Use and install the Product only for its intended purpose.
2. To avail yourself of this Limited Warranty, return the Product with a copy of the paid receipt, postage paid to: MARCH PERFORMANCE 16160 PERFORMANCE WAY NAPLES, FL 34110
3. When returning the Product, you must follow the directions set forth on the Warranty/Return Form on the reverse side of this Limited Warranty. If you no longer have the Warranty/Return Form, one may be obtained by contacting March Performance during normal business hours at: (888) 729-9070.
4. Shipping and/or transportation costs returning the Product to March Performance and any damage caused during shipping are your responsibility. March Performance will pay for shipping and/or transportation costs incurred in returning the Product to you.

LIMITED WARRANTY WARRANTY/RETURNS FORM

No product mounted is considered for credit unless it is a manufacturer defect.

All products returned for any reason must reference an authorization number (RGA). The RGA number is obtained by calling place of purchase during normal business hours. Any product returned without the RGA# written on the return package next to the return shipping label will be refused.

All returns must ship via UPS and be properly packaged in the original carton. Return freight charges are the responsibility of the customer unless the product was shipped in error.

March product returned after (1) year from date of purchase will not be accepted unless it is found to be a manufacturer defect. The customer must include a written statement describing the alleged product defect. The complete Limited Warranty is set forth on the reverse side.

- 100% credit issued on manufacturer defects
20% return fee on all reshelvable product
30% return fee on all repairable product

NO CREDIT WILL BE ISSUED ON RETURNED PRODUCT BEYOND REPAIR

March Performance thoroughly inspects all returns. It is the sole discretion of March Performance in determining the condition of all returned merchandise.

To receive replacements at no charge the original product must first be received and inspected by March Performance for determination. Immediate replacements may be purchased and later credited upon inspection determination.

Please Complete the Information below, detach and include with returned product.

Form fields for RGA#, CT#, Issued by, Date, Purchaser's Name, Phone, Address, Purchased Directly Through, Invoice#, Product ID, Invoice Date, Reason.

** MOUNTED PRODUCTS ARE NONREFUNDABLE **