

# Ford 351 Cleveland Alternator Bracket Kit

## Parts List

- 1-(30400) Assembly
  - 1-(30400-A) Alt. Bracket
  - 1-(30400-B) Alt. Support Bracket
- 2-(S148) 5/16-18 x 1 1/4 SHCS (mount A to B)
- 2-(TP5-.800) 5/16 x .800 spacer tube (between A & B)
- 1-(S376) 7/16-14 x 6" SHCS (30400-B & alternator to cylinder head)
- 1-(TP7-2.250) 7/16 x 2 1/4 spacer tube (between alternator & cylinder head)
- 2-(S162) 5/16-18 x 3" SHCS (30400-A & waterpump to engine block)
- 1-(TP5-.350) 5/16 x .350 spacer tube (between 30400-A & waterpump)
- 1-(30005) alt relocater
- 1-(S248) 3/8-16 x 1" SHCS (alt relocater to alt)
- 1-(SS 2.500) stainless steel rod assembly
- 1-(S250) 3/8-16 x 1 1/4 SHCS (SS rod assembly to alt relocater)
- 1-(S622) 3/8-16 nylon locknut (SS rod assembly to alt relocater)
- 1-(S310) 5/16-18 x 3/8 shoulder bolt (SS rod assembly to 30400-A alt bracket)

30400 Power Steering Kit uses a 36" V-belt with March performance ratio pulleys

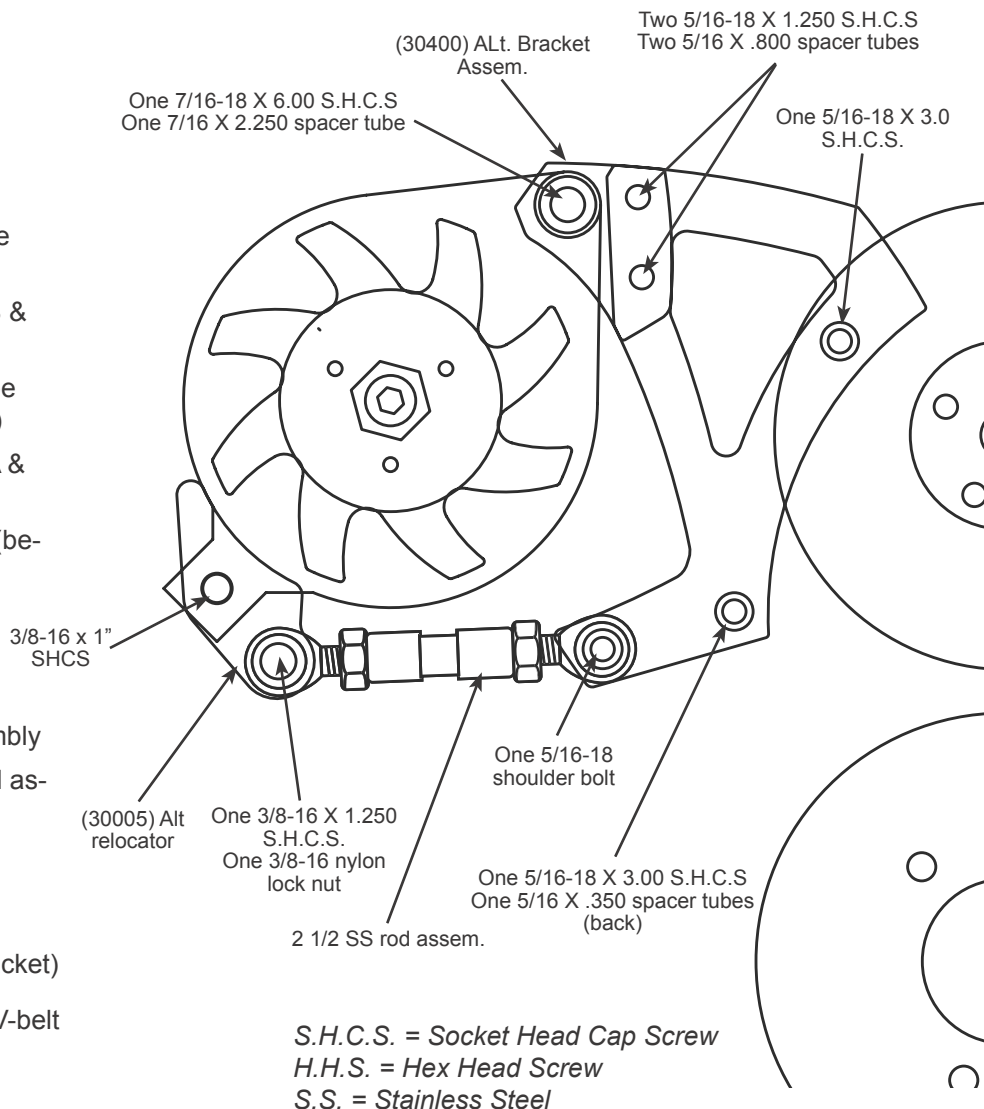

## Assembly Instructions

1. Bolt (30400) Alt. Bracket Assembly & waterpump to engine block using two (S162) 5/16-18 x 3" socket head cap screw. Place one (TP5-.350) 5/16 x .350 spacer tube between (30400) Alt. Bracket Assembly (bottom hole) & waterpump (do not tighten completely yet).
2. Bolt (30400) Alt. Bracket Assembly & alternator to cylinder head using one (S376) 7/16-14 x 6" socket head cap screw & one 7/16 x 2 1/4 spacer tube (between alternator & cylinder head).
3. Bolt (30005) alt relocater to alternator using one (S248) 3/8-16 x 1" socket head cap screw.
4. Bolt one end of (SS 2.500) stainless steel rod assembly to alt relocater using one (S250) 3/8-16 x 1 1/4 socket head cap screw & one (S622) 3/8-16 nylon locknut.
5. Bolt other end of (SS 2.500) stainless steel rod assembly to (30400) Alt. Bracket Assembly using one (S310) 5/16-18 x 3/8 shoulder bolt.
6. Install belt. Adjust belt tension using (SS 2.500) stainless steel rod assembly.



#30405

Revised 7-1-06

# Ford 351 Cleveland Power Steering Bracket Kit

## Parts List

- 1-(30405-A) P/S Bracket
  - 1-(30405-B) P/S. Support Bracket
  - 2-(S244) 3/8-16 x 3/4" SHCS (30405-A P/S Bracket to waterpump)
  - 1-(S313) 3/8-16 x 1 1/4" HHS (30405-A P/S Bracket to p/s pump- top slot)
  - 3-(S664) 3/8 x 1 x .080 washers (2 between 30405-A P/S Bracket & P/S pump, 1 front)
  - 1-(AC3-.500) 3/8 x 1 x .500 spacer (between 30405-A P/S Bracket & P/S pump)
  - 1-(S321) 3/8-16 x 1 3/4" HHS (30405-B P/S Support Bracket to back of p/s pump)
  - 1-(S322) Front bracket to lower to p/s pump)
  - 1-(S379) 7/16-14 x 2" HHS (30405-B P/S Support Bracket to engine block)
- 30405 Power Steering Kit uses a 46" V-belt with March performance ratio pulleys

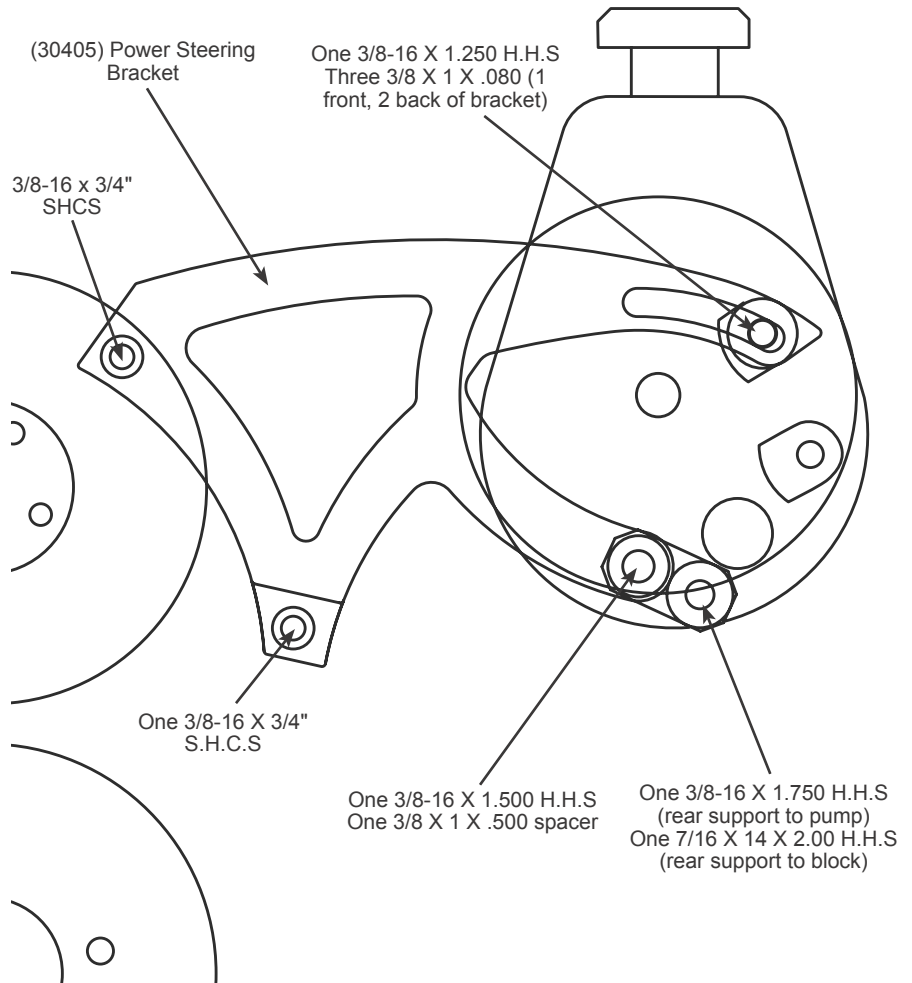

S.H.C.S. = Socket Head Cap Screw  
H.H.S. = Hex Head Screw  
S.S. = Stainless Steel

## Assembly Instructions

1. Bolt (30405-A) P/S Bracket & waterpump to engine block using two (S244) 3/8-16 x 3/4 socket head cap screws.
2. Bolt bottom of power steering pump to (30405-A) P/S Bracket using one (S322) 3/8-16 x 1 1/2 hex head screw & one (AC3-.500) 3/8 x 1 x .500 spacer between 30405-A P/S Bracket & p/s pump.
3. Bolt top of power steering pump to (30405-A) P/S Bracket using one (S313) 3/8-16 x 1 1/4 hex head screw & three (S664) 3/8 x 1 x .080 washers (2 between 30405-A P/S Bracket & p/s pump, 1 in front). Leave loose for adjustment.
4. Bolt (30405-B) P/S Support Bracket to back of p/s pump using one (S321) 3/8-16 x 1 3/4 hex head screw. Bolt other side of (30405-B) P/S Support Bracket to engine block using one (S379) 7/16-14 x 2" hex head screw.
5. Install belt. Adjust belt tension by pulling out on p/s pump. Tighten (S313) 3/8-16 x 1 1/4 hex head cap screw to lock in position.